

VCS II - 2 GENERATION VARIO COMPACT ABS

RESERVEDELE
TIL LASTBILER
ANHÆNGERE
OG BUSSE

Strømforsyning	
Split	Lige
<p>■ = ECU Standard 400.500.070.0</p> <p>■ = ECU Premium 400.500.081.0 / 082.0</p> <p>■ = ECU Separat 446.108.085.0</p>	
<p>ISO7638(5-ben)</p> <p>449.132.005.0 0,5 m</p> <p>449.132.060.0 6 m</p> <p>449.132.080.0 8 m</p> <p>449.132.120.0 12 m</p> <p>449.132.150.0 15 m</p> <p>449.242.100.0 10 m</p> <p>449.375.003.0 0,3 m</p> <p>449.375.030.0 3 m</p> <p>449.375.060.0 6 m</p> <p>449.375.100.0 10 m</p>	<p>ISO7638(5-ben)</p> <p>449.125.060.0 6 m</p> <p>449.125.100.0 10 m</p> <p>449.125.120.0 12 m</p> <p>449.125.140.0 14 m</p> <p>449.125.180.0 18 m</p> <p>449.225.060.0 6 m</p> <p>449.225.120.0 12 m</p> <p>449.225.140.0 14 m</p>
<p>ISO7638(5-ben)/24N</p> <p>449.374.281.0 0,25m/8m</p> <p>449.374.323.0 1m/12m</p>	<p>ISO7638(5-ben)/24N</p> <p>449.124.333.0 6m/12m</p> <p>449.124.337.0 12m/12m</p> <p>449.224.328.0 3m/12m</p> <p>449.224.337.0 12m/12m</p>
<p>ISO7638(7-ben)</p> <p>449.133.030.0 3 m</p> <p>449.133.120.0 12 m</p> <p>449.133.150.0 15 m</p> <p>449.233.030.0 3 m</p> <p>449.233.100.0 10 m</p> <p>449.233.140.0 14 m</p> <p>449.233.180.0 18 m</p> <p>449.385.003.0 0,3 m</p> <p>449.385.030.0 3 m</p> <p>449.385.060.0 6 m</p> <p>449.385.100.0 10 m</p>	<p>ISO7638(7-ben)</p> <p>449.126.060.0 6 m</p> <p>449.126.100.0 10 m</p> <p>449.126.120.0 12 m</p> <p>449.126.140.0 14 m</p> <p>449.226.060.0 6 m</p> <p>449.226.100.0 10 m</p> <p>449.226.120.0 12 m</p> <p>449.226.140.0 14 m</p>
<p>ISO7638(7-ben)/24N</p> <p>449.384.323.0 1 m/12 m</p> <p>449.384.333.0 6 m/12 m</p>	<p>ISO7638(7-ben)/24N</p> <p>449.234.337.0 12 m/12 m</p>
<p>ISO7638(7-ben)+Diagn.</p> <p>449.133...+449.233...+</p> <p>449.386.143.0 1 m/3 m</p> <p>449.386.148.0 3 m/3 m</p>	<p>ISO7638(7-ben)+Diagn.</p> <p>449.144.057.0 12 m/1 m</p> <p>449.144.157.0 12 m/3 m</p> <p>449.244.048.0 3 m/1 m</p> <p>449.244.055.0 8 m/1 m</p> <p>449.244.155.0 8 m/3 m</p> <p>449.244.157.0 12 m/3 m</p>
<p>Strømkabel (5-ben)</p> <p>449.345.120.0 12 m</p> <p>449.345.150.0 15 m</p>	<p>Strømkabel (7-ben)</p> <p>449.320.120.0 12 m</p> <p>449.320.150.0 15 m</p>

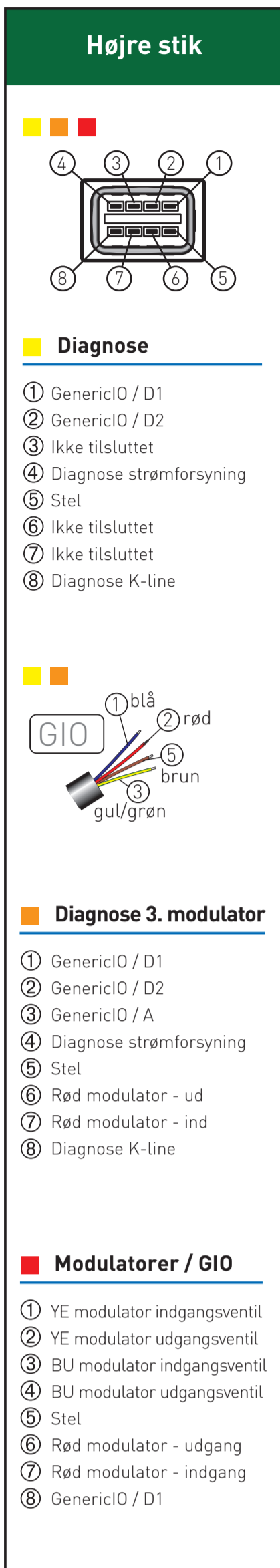
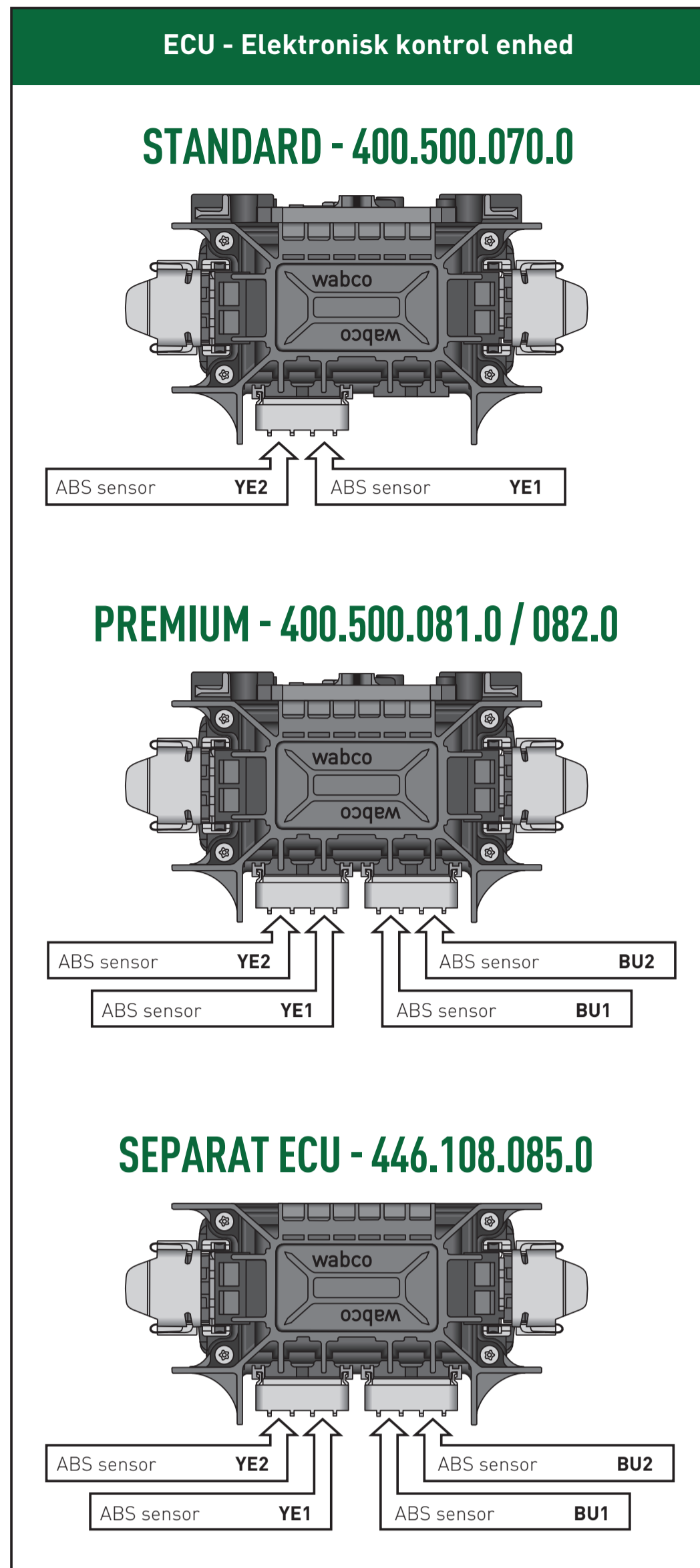
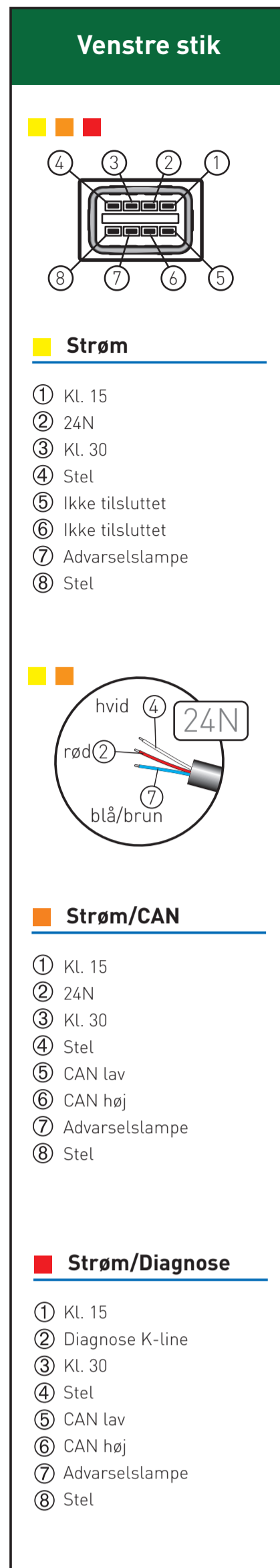

Diagnose kabel

<p>ECAS / diagnose kabel</p> <p>449.336.030.0 3 m</p>	<p>Diagnose kabel + slidindikator</p> <p>449.619.148.0 3 m/3 m</p>
<p>ECAS/diagnose kabel + Amodulator</p> <p>449.337.328.0 3 m/12 m</p>	<p>Diagnose kabel + ELM</p> <p>449.340.253.0 6 m/6 m</p> <p>449.340.316.0 10 m/10 m</p>
<p>Diagnose kabel + retur til kørehøjde</p> <p>449.623.253.0 6 m/6 m</p>	<p>Diagnose kabel +GenericIO</p> <p>449.615.030.0 3 m</p> <p>449.615.060.0 6 m</p> <p>449.617.253.0 6 m/6 m</p> <p>449.617.257.0 12 m/6 m</p>

Diagnose kabel + modulator

<p>Diagnose kabel +GIO+Amodulator</p> <p>449.618.153.0 6 m/3 m</p> <p>449.618.157.0 12 m/3 m</p>	<p>Diagnose kabel +Amodulator</p> <p>449.616.148.0 3 m/3 m</p> <p>449.616.153.0 6 m/3 m</p> <p>449.616.156.0 10 m/3 m</p> <p>449.616.157.0 12 m/3 m</p> <p>449.616.158.0 15 m/3 m</p> <p>449.616.235.0 8 m/5 m</p> <p>449.616.253.0 6 m/6 m</p>
<p>Diagnose kabel + A modulatur + slidindikator</p> <p>449.620.156.0 10 m/3 m</p>	<p>Modulator kabel YE+BU+GIO</p> <p>449.555.293.0 6 m/8 m</p>
<p>Modulator kabel A + B + C + GIO</p> <p>449.566.333.0 6 m/8 m</p>	<p>Modulator kabel YE+BU+RD</p> <p>449.544.190.0 4 m/4 m</p> <p>449.544.248.0 3 m/6 m</p> <p>449.544.333.0 6 m/12 m</p>
<p>Modulator kabel</p> <p>449.534.043.0 1 m/1 m</p> <p>449.534.148.0 3 m/3 m</p> <p>449.534.253.0 6 m/6 m</p>	

Sensor

<p>Sensorkabel</p> <p>449.712.008.0 0,76 m</p> <p>449.712.018.0 1,78 m</p> <p>449.712.023.0 2,3 m</p> <p>449.712.030.0 3,0 m</p> <p>449.712.038.0 3,81 m</p> <p>449.712.051.0 5,08 m</p> <p>449.712.060.0 6,0 m</p> <p>449.712.064.0 6,35 m</p> <p>449.712.070.0 7,0 m</p>	<p>Mini sensor og kabel / Mini sensor bøsning</p> <p>Mini sensor bøsning 899.759.882.4</p> <p>Mini sensor + kabel 441.035.001.0 0,5 m</p>	<p>Sensor og kabel / Sensor og bøsning</p> <p>Sensor bøsning 899.760.510.4</p> <p>Sensor + kabel 441.032.808.0 0,4 m</p> <p>441.032.809.0 1,0 m</p> <p>Sensor + bøsning + fedt 441.032.921.2 0,4 m</p> <p>441.032.922.2 1,0 m</p>
---	--	--

PC Diagnose

Software 246.301.5.0

Interface sæt (incl. CabletoPC) 446.301.021.0 (COM)

446.301.022.0 (USB)

Diagnosekabel 446.300.329.2

Dobbelt løsnerventil

Med integreret retur stop ventil 963.001.051.0

Uden integreret retur stop ventil 963.001.052.0

Lufttank

	liter	dia.
950.560.001.0	60	246 mm
950.760.002.0	60	276 mm
950.060.003.0	60	310 mm
950.060.004.0	60	396 mm
950.080.002.0	80	396 mm

Alvandsingsventil 934.300.001.0

Ophæng for lufttank

diam.	451.999.246.2	451.999.276.2	451.999.310.2	451.999.396.2
246 mm	451.999.246.2	451.999.276.2	451.999.310.2	451.999.396.2

ABS relæ magnet ventil (modulator)

472.195.031.0

Valgfri for 4S/3M

Koblingshoveder (m. integreret filter)

Tilførsel 952.201.012.0

Kontrol 952.201.011.0

Kontrol og test nippel 952.201.013.0

For mekanisk affjedring 899.144.630.4

For luftaffjedring 899.144.631.4

ALB skilte

Relæ ventiler

Uden forlring 971.002.301.0

Justérbar forlring 971.002.300.0

ALB ventiler

For mekanisk affjedring 475.713.500.0

For luftaffjedring (billede) 475.714.500.0

Membran cylindere

Type	423.104.900.0	423.105.900.0	423.106.900.0	423.107.900.0
16	423.104.900.0	423.105.900.0	423.106.900.0	423.107.900.0

Fjederbremse cylinder

Type	925.370.307.0	925.371.300.0	925.372.307.0
20/30	925.370.307.0	925.371.300.0	925.372.307.0

VCSII ABS

Premium (2S/2M-4S/3M) 400.500.081.0/082.0

Valgfri: Standard (2S/2M) 400.500.070.0

Hurtig udlufter ventil

4-porte + integreret dobbelt tjek ventil 973.500.051.0

KONTAKT TEKNISK SUPPORT PÅ: TLF 76 34 82 10

BESKO