

# LASTBIL EBS 5 KNORR-BREMSE

RESERVEDELE  
TIL LASTBILER  
ANHÆNGERE  
OG BUSSER

### 1. Gyro sensor (YRS)

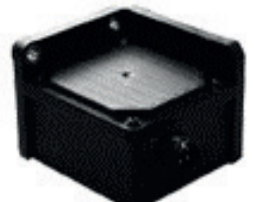

Eftermarkedsnummer:	
MAN	0486020007N50
Renault Trucks	0486020007N50
Scania	0486020007N50
Volvo	0486020007N50

Gyro sensoren (YRS) overvåger køretøjets side acceleration.  
Note: Gyro sensor skal kalibreres efter installation.  
Kontakt BESKO Teknisk Support.

### 2. Styrevinkel sensor, vinkel (SAS)

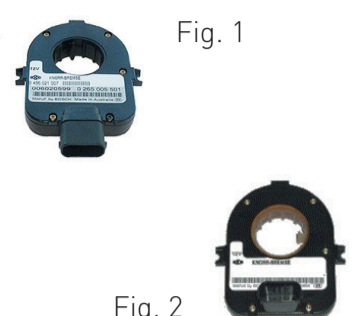



Fig. 1	Fig.	Eftermarkedsnummer:
	MAN	1 0486021007N50
	Scania	2 0486021003N50
	Volvo	2 0486021003N50

Styrevinkel sensoren overvåger den ønskede styretøjssposition.  
Note: Styrevinkel sensor skal kalibreres efter installation.  
Kontakt BESKO Teknisk Support.

### 3. Trykmodulator (ABS)



Eftermarkedsnummer:	
MAN	II17776N00*
Renault Trucks	II17776N00*
Scania	II17776N00*
Scania	K015677N00**
Volvo	II17776N00*

### 4. Trailer kontrol modul (TCM)

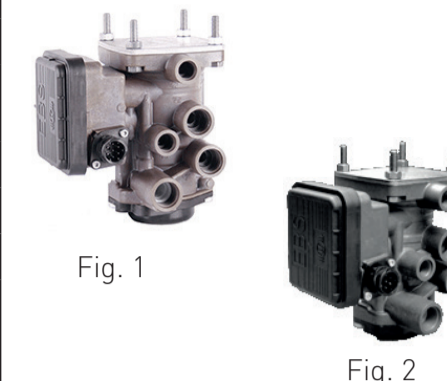

Fig.	Eftermarkedsnummer:
MAN	1 K020623N50
Renault Trucks - Magnum	1 K020623N50
Renault Trucks	2 K020626N50
Scania	1 K020623N50
Volvo	1 K020624N50

Trailer kontrol modul (TCM) kontrollerer trailerens afbremsning og giver optimal trækker/trailer kompatibilitet.

### ABS sensorer





Fig.	Tilslutning	Længde (mm)	Reserveudsnummer (IAM)
1	Plug type round	1250	0486000116100
1	Plug type round	2095	0486000118100
2	Plaselec	2100	0265050141000
2	Plaselec	2100	0265050142000
3	Socket type round	2000	0486000182100
1	Plug type round	1990	0486000183100
1	Plug type round	1390	0486000273100
4	Plug type round	2050	0486001077100
13	Schlemmer	2500	0486001077100
13	Schlemmer	2500	0486000103N00
6	Open	2000	0486000130100
5	Schlemmer	2555	0486000172000
5	Schlemmer	2555	0486000173000
6	Open	3555	0486000222100
5	Schlemmer	1300	0486000233181
5	Schlemmer	2000	0486000234181
5	Schlemmer	1300	0486000235181
5	Schlemmer	2000	0486000236181
5	Schlemmer	1300	0486000237N00
5	Schlemmer	2000	0486000238N00
5	Schlemmer	1300	0486000239N00
5	Schlemmer	2000	0486000240N00
5	Schlemmer	2000	0486000241N00
5	Schlemmer	2000	0486000242N00
5	Schlemmer	3555	0486000243N00
5	Schlemmer	3555	0486000244N00
5	Schlemmer	3555	0486000245N00
5	Schlemmer	3555	0486000246N00
7	G & H	1500	0486000250N00
7	G & H	1500	0486000251N00
7	G & H	1850	0486000252N00
7	G & H	1850	0486000253N00
7	G & H	2150	0486000254N00
7	G & H	2150	0486000255N00
7	G & H	2150	0486000256N00
7	G & H	2150	0486000257N00
7	G & H	2800	0486000258N00
7	G & H	2800	0486000259N00
7	G & H	1800	0486000260N00
7	G & H	1800	0486000261N00
7	G & H	3900	0486000262N00
7	G & H	3900	0486000263N00
7	G & H	1100	0486000276N00
7	G & H	1100	0486000277N00
12	MKR Plus	1000	0486000284N00
12	MKR Plus	1350	0486000285N00
11	Socket type round	300	0486001032100
8	Schlemmer	2000	0486001041N00
8	Schlemmer	2000	0486001042N00
10	G & H	2600	0486002001000
10	G & H	2600	0486002002000
3	Socket type round	1400	0486000039000
3	Plug type round	1390	0486000040000
7	Deutsch	2400	0486000071000
7	Deutsch	2400	0486000072000
9	Open	1895	0265050112000
10	Deutsch DT	2350	0486002003N00
10	Deutsch DT	2350	0486002004N00

### 9. Elektronisk kontrol enhed (ECU)



Reserveudsnummer (IAM)	
Iveco - Irisbus	0486106307N50
MAN	0486106303N50
MAN	0486108003N50
Renault trucks	0486106305N50
Scania	0486106306N50
Volvo	0486106304N50
Volvo	0486108004N50

Elektronisk kontrol enhed (ECU) - til alle EBS funktioner

Note: Udskiftning af ECU forudsætter programmering af køretøjet. Dette kan foretages ved hjælp af multi diagnose System. For hjælp med at finde den rigtige ECU, Kontakt BESKO Teknisk Support og oplys det originale nummer, som står på enheden.

### 8. 1-kanals elektronisk tryk modul (EPM)



Reserveudsnummer (IAM)	
Iveco - Irisbus	K021203N50
MAN	K021204N50
Renault Trucks	K021203N50
Scania	K021202N50
Volvo	K021202N50

1 - kanal Elektro-Pneumatisk Modul (EPM). En samlet enhed med magnetventiler, relæ ventiler, tryk sensorer og elektronik, som behandler informationer fra ABS sensorer og bremsebelægnings sensorer.

### Diagram (luft)

- Forsyning
- ESS Signal
- Fodbremse
- Parkeringsbremse

### Diagram (elektrisk)

- CAN - signal (kontrol)
- CAN - signal (trailer)
- CAN - signal (ESP)
- CAN - signal (J1939)
- Elektrisk signal
- WL Advarselstampe
- IL Informationslampe

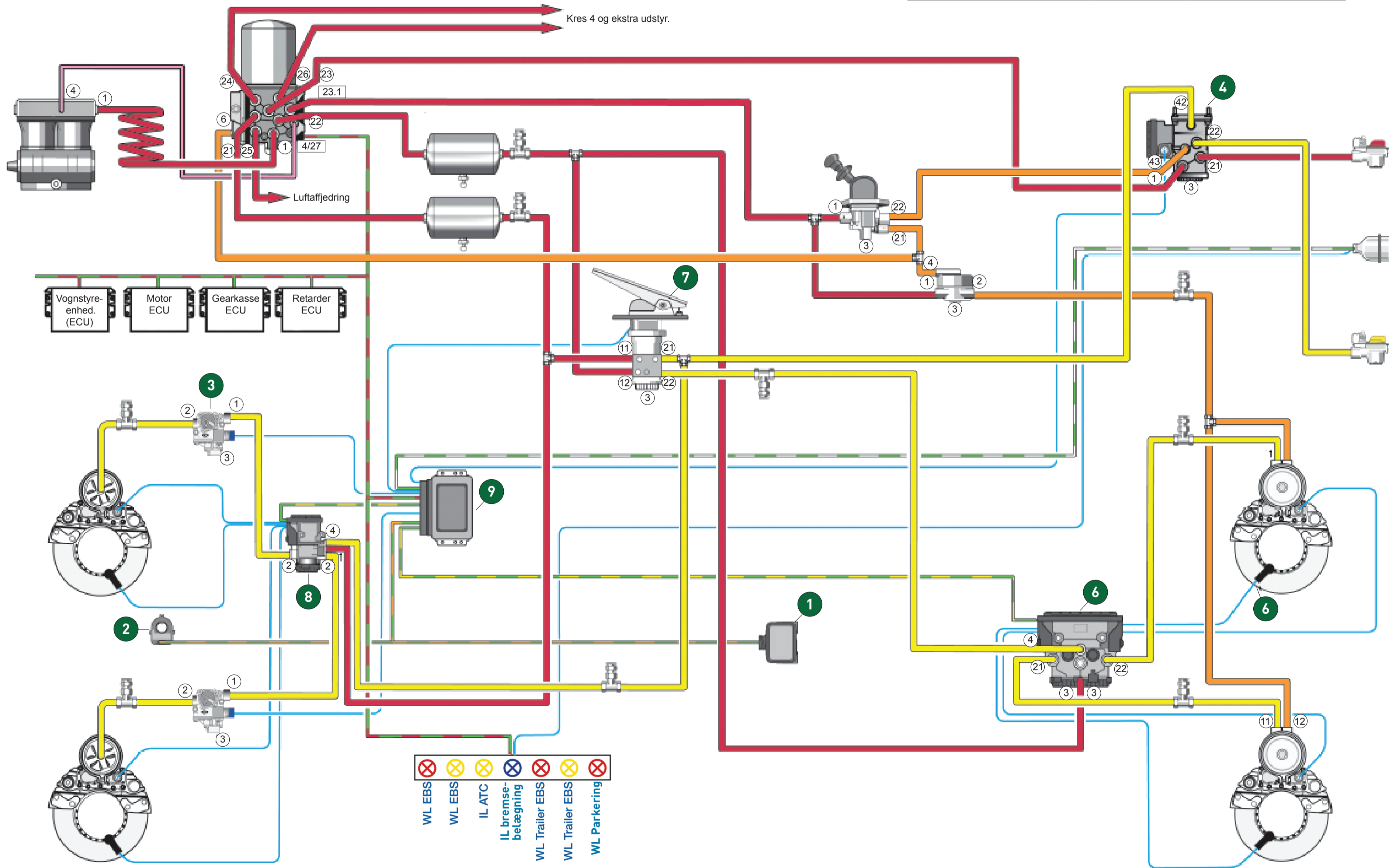

### 7. Fodbremse modul (FBM)

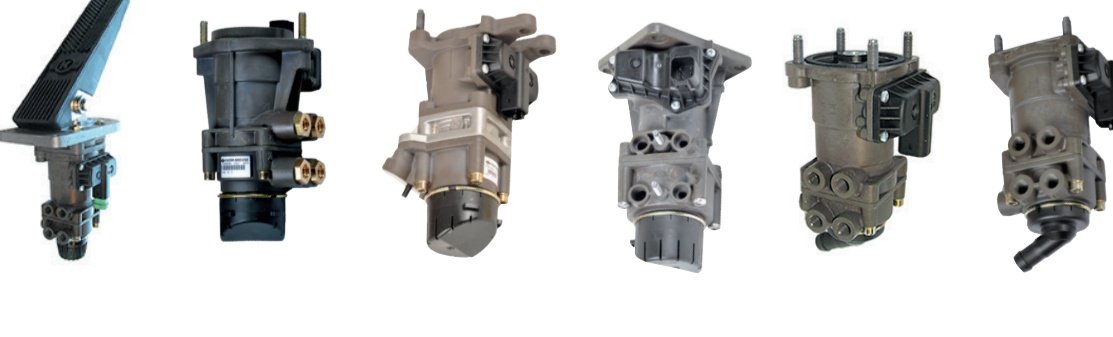

Fig.	Eftermarkedsnummer:
1	K024928N50
2	K039569N50
2	K039571N50
3	K040158N50
3	K040156N50
4	K044696N50
5	K044694N50
6	K040159N50
1	K024928N50

### 6. 2-kanals elektronisk tryk modul (EPM) (Bagaksel)



Fig.	Reserveudsnummer (IAM)
1	K020023N50
1	K020024N50
2	K023216N50
1	K023215N50
1	K032014N50
1	K020023N50

2-kanals elektronisk modul (EPM).

Fig.	Tilslutning	Længde (mm)	Reserveudsnummer (IAM)
Iveco	1 Plug type round	1250	0486000116100
Iveco	1 Plug type round	2095	0486000118100
Iveco - Irisbus	2 Plaselec	2100	0265050141000
Iveco - Irisbus	2 Plaselec	2100	0265050142000
Iveco - Irisbus	3 Socket type round	2000	0486000182100
Iveco - Irisbus	1 Plug type round	1990	0486000183100
Iveco - Irisbus	1 Plug type round	1390	0486000273100
Iveco - Irisbus	4 Plug type round	2050	0486001077100
MAN	13 Schlemmer	2500	0486001077100
MAN	13 Schlemmer	2500	0486000103N00
MAN	6 Open	2000	0486000130100
MAN	5 Schlemmer	2555	0486000172000
MAN	5 Schlemmer	2555	0486000173000
MAN	6 Open	3555	0486000222100
MAN	5 Schlemmer	1300	0486000233181
MAN	5 Schlemmer	2000	0486000234181
MAN	5 Schlemmer	1300	0486000235181
MAN	5 Schlemmer	2000	0486000236181
MAN - Bus	5 Schlemmer	1300	0486000237N00
MAN - Bus	5 Schlemmer	2000	0486000238N00
MAN - Bus	5 Schlemmer	1300	0486000239N00
MAN - Bus	5 Schlemmer	2000	0486000240N00
MAN - Bus	5 Schlemmer	2000	0486000241N00
MAN - Bus	5 Schlemmer	2000	0486000242N00
MAN	5 Schlemmer	3555	0486000243N00
MAN	5 Schlemmer	3555	0486000244N00
MAN	5 Schlemmer	3555	0486000245N00
MAN	5 Schlemmer	3555	0486000246N00
MAN	7 G & H	1500	0486000250N00
MAN	7 G & H	1500	0486000251N00
MAN	7 G & H	1850	0486000252N00
MAN	7 G & H	1850	0486000253N00
MAN - Bus	7 G & H	2150	0486000254N00
MAN - Bus	7 G & H	2150	0486000255N00
MAN - Truck & Bus	7 G & H	2150	0486000256N00
MAN - Truck & Bus	7 G & H	2150	0486000257N00
MAN	7 G & H	2800	0486000258N00
MAN	7 G & H	2800	0486000259N00
MAN	7 G & H	1800	0486000260N00
MAN	7 G & H	1800	0486000261N00
MAN	7 G & H	3900	0486000262N00
MAN	7 G & H	3900	0486000263N00
MAN	7 G & H	1100	0486000276N00
MAN	7 G & H	1100	0486000277N00
MAN	12 MKR Plus	1000	0486000284N00
MAN	12 MKR Plus	1350	0486000285N00
MAN	11 Socket type round	300	0486001032100
MAN	8 Schlemmer	2000	0486001041N00
MAN	8 Schlemmer	2000	0486001042N00
MAN	10 G & H	2600	0486002001000
MAN	10 G & H	2600	0486002002000
Renault Trucks	3 Socket type round	1400	0486000039000
Renault Trucks	3 Plug type round	1390	0486000040000
Renault Trucks	7 Deutsch	2400	0486000071000
Renault Trucks	7 Deutsch	2400	0486000072000
Scania	9 Open	1895	0265050112000
Scania - Bus	10 Deutsch DT	2350	0486002003N00
Scania - Bus	10 Deutsch DT	2350	0486002004N00

ABS sensorer generer hastighedssignal fra hvert enkelt hjul.

Kontakt Teknisk support på: Tlf 76 34 82 10